

PLH3D-2W

Operating Manual



Contact and Shipping:
Tomorrow's System Sp. Z o.o.

*Okulickiego 7/9 hala G39
05-500 Piaseczno
Poland
tel.: +48 515 180 752*

Company Information:
Tomorrow's System Sp. Z o.o.

*Pułaskiego 125/35
15-337 Białystok
Poland
NIP: PL5423238556*

Table of Content

- General Laser Safety Warnings and Cautions..... 3
- Product description 4
- Technical Data..... 6
- Connection of the laser head 6
- Setting the focal length/distance 7
- Recommendations and requirements 8
- Protection..... 8
- Parameters of cutting..... 11

General Laser Safety Warnings and Cautions

Only person with specialized training and appropriate laser safety knowledge can use and maintain the laser head. The laser head operator must be aware of laser radiation hazard.

While laser head is operating protection Laser Glasses designed for 190 – 540 nm should be used. Make sure that all personnel in the same room worn protection glasses.

Eye exposure to the direct or diffusely reflected laser beam is a hazard. The laser head beam may cause permanent eye damage.

Skin exposure to the laser beam is a hazard. The laser beam may cause serious skin burns. Laser beam may easily burn cloth.

It is possible to get serious injury while using this product or being in the vicinity of an individual using it. Improper use of the laser head can result in injury or death.

Flammable substances exposure to the laser beam may pose fire hazard. The laser head operation in an explosive atmosphere may be dangerous. The working area must be well ventilated. During the operation laser beam may ignite gases or flammable liquids.

Before making any adjustments, changing accessories or performing maintenance, the laser should be powered off and disconnected from the power supply and CNC main board.

The laser head must be properly mounted to a rigid body such that it cannot be moved unintentionally. Unintentional move of the laser head is dangerous.

The unauthorized personnel must have no access to the system into which the laser head is integrated. The laser head must be stored out of the reach of children. Untrained persons are not allowed to operate, maintain and observe operation of the laser head.

Do not place high-reflectivity materials in front of operating lasers head. Remember, diffused reflection of the laser beam is uncontrolled and may pose hazard to eye.

Appropriate shielding should be used around the system into which the laser head is integrated. The system in which laser head is used must be equipped with key switch and safety interlock.

Responsibility of use or misuse belongs to the end user. Tomorrow's System and its affiliates accept no responsibility for use or misuse by the user. If you may not be able to use this product properly, we recommend that you do not begin use or cease use immediately.

Product description



This sub-assembly is a medium power engraving laser head with thermal protection and professional high speed driver. Its design ensures that the head doesn't require any additional cooling. Fan design makes it work as a fully customized air nozzle protecting lens from dirt and cooling the laser head.

PLHD 3D 2W driver ensures proper work of the laser head and protects laser diode from overheating. During normal work green diode is turned on. When the laser head reaches 40 degrees Celsius second LED diode starts to glow. At 45 degrees the laser head switches off.



Turning collimating lens allows to change the beam focus distance. Air flow from the fan keeps lens clean during operation.

You can use two types of lens with our PLH3D laser heads. G2 lenses are popular because of the efficiency but it is not the most important parameter. While engraving, power density is more important - unfortunately G2 lenses are not providing small beam spot (while focused). Three element lens which are making bigger optical power loss allows to obtain smaller beam spot which helps to obtain bigger power density. The choice is up to customer's requirements, since in some situation it is better to use G2 lens and sometimes three element lens.

The laser head allows to cut or engrave materials such as rubber, wood, paper, leather, plastic, cardstock and many other. Thanks to full analog modulation it is possible to engrave in shades of grey or change the output power during turns. The same effect can be achieved by using PWM signal which is fully compatible with PLH3D driver. High speed modulation (up to 100 kHz) allows to use high movement speed during engraving even complicated patterns.

Module is using brand new NDB7875 450nm diode which is one of the strongest available on market blue laser diode. Recommended power supply unit is 12V with current capacity at least 2A. On our website there are available DC-DC converters which allows to easily change any higher voltage into 12V.



Lifetime of laser diode given by manufacturer is 10000h.

It is also possible to buy a version with additional aluminum holder which allows to mount the engraving laser head on the moving part of the machine.

Main advantages of the PLH3D 2W:

- Easy connection to all 3D printers and CNC machines producers.
- Dedicated software - G-code generator

- No need for additional cooling.
- Simple installation to all 3D printers and CNC routers
- Driver attached to the laser head.

Technical Data

Dimensions of laser head (LxWxH mm)	30 x 30 x 68,5
Modulation voltage range (V)	0 - 5
Modulation type	TTL or analog
Input voltage (V)	12
Mounting holes distance (mm)	20
Focus distance (mm)	20 - 120
Diode power (W)	2.8
Maximum power consumption (W)	15
Noise (dBA)	23
Weight (g)	70
Example beam spot size at 80mm distance	0,1 x 0,18 mm
Internal part no	001633

Connection of the laser head

Connecting engraving laser head is very simple and is using 4-pin connector. To each device 4-pin connector is included.

Caution:

Remember to use both of GND cables

Pins #2 and #3 should be connected to proper power supply unit which also can be buy at our website or together with laser head. Pin #4 should be connected with GND of the modulation signal source while pin #1 to the source of 0 - 5 V signal which is responsible for power modulation.



1 – Analog in 0-5V

2 –Vcc 12V (minimal current provided: 2A)

3 – GND

4 – Analog GND

Additional single lens collimator is attached. Premounted three element lens collimator is 30% less efficient but it has 2 times smaller spot. You can check which one works the best for you.

Setting the focal length/distance

Setting the focus distance should be firstly done by turning the lens and then, after making the lens not move, by using your Z axis in CNC machine. Focus depends on type of lens used and their distance from laser diode. Remember, do not change the position of the lens while laser is operating. Switch the laser each 0,5 turn of the lens in order to check beam spot position.

Be careful not to unscrew the lens accidentally – the lens can fall down and get dirty/destroyed. For three element lenses focus length should be in range between 120 and 40mm. For single element lens it should be in range between 100 and 20mm. Nevertheless, accurate focus distance should be set according to the test made with your material.

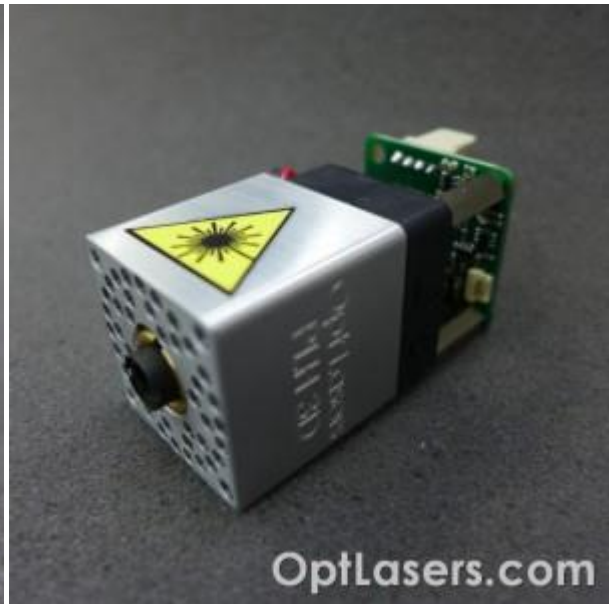
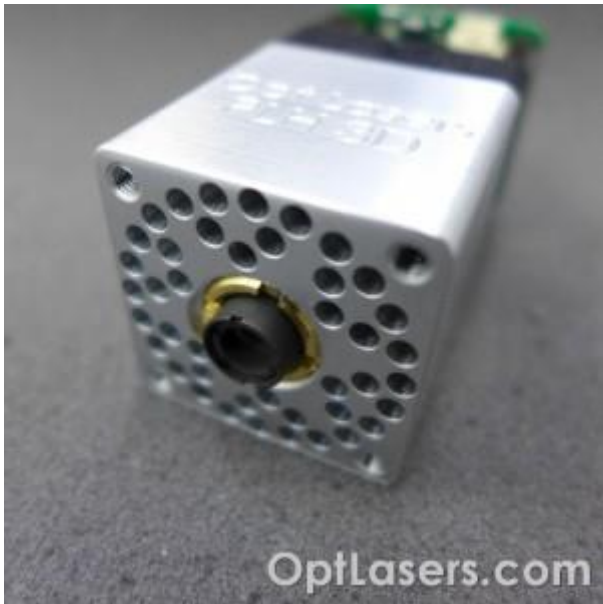

Recommendations and requirements

Modulation input can be used as TTL/PWM input with its logic levels of 0V and 5V or as an analog input. Analog modulation means that by using 2,5 V on ANG input you get 50% output power, analogically by using 4 V you obtain 80% output power, etc.

Cleaning the optics is important since dirty optics reflect some % of power back to the diode what may be damage it irreparably.

Air flow is very important during the engraving process since it is blowing out dark smoke which can cause optical obstacle for a laser beam.

Protection

This module has thermal protection system which protect laser diode from overheating.

The analog input is protected by a 5V1 Zener diode on occasion there appears the voltage higher than 5V. Despite everything, this input should not be used with higher voltages.

The output of the driver is protected by Schottky diode which doesn't allow the reverse voltage to appear.

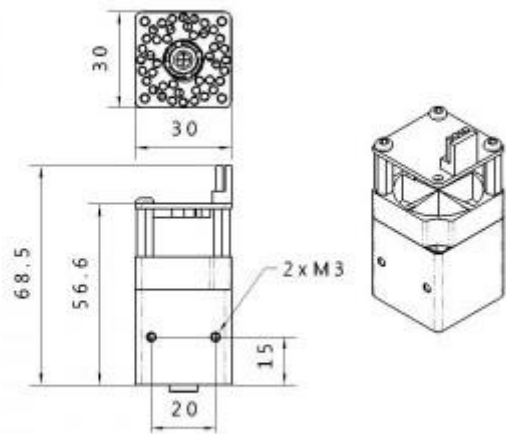

OptLasers.com

Dimensions of the PLH3D - 2W

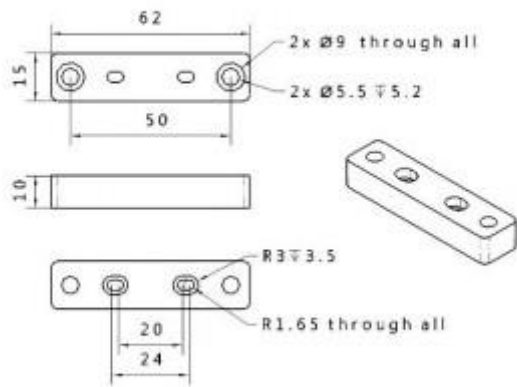

OptLasers.com

Dimensions of the aluminum mount



PLH3D 2W with aluminium holder



Additional components (depending on set, different parts are included)

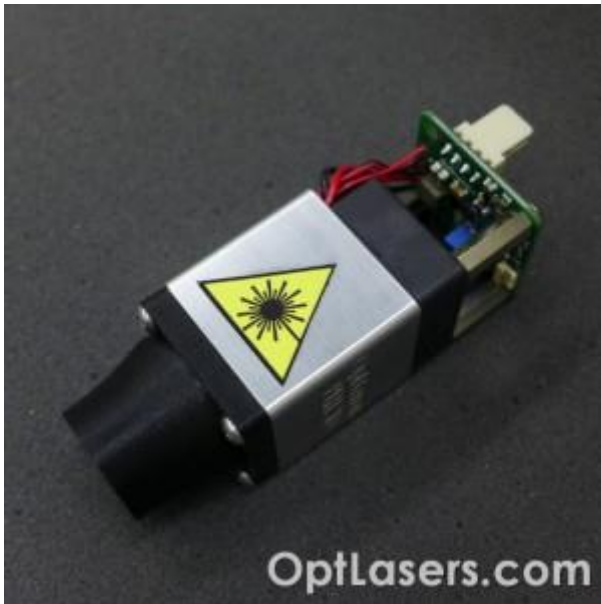

PLH3D-2W with ABS nozzle

Parameters of cutting

Note, that this speeds and parameters are effects of tests and can be different for some materials, cooling systems as well setting of the focus distance.

Binder board 3mm: 5mm/s; **2W;** 8x0,5 **passes**

Balsa 5mm: 25mm/s; **2W;** **5 passes**

5-layer cardboard 5 mm: 10mm/s; **2W;** 4x1,25

Rubber 0,5mm: 15mm/s; **2W;** 3x0,25

Jeans 0,5mm: 8mm/s; **2W;** **1pass**

T-shirt 0,5mm: 25mm/s **2W** 1 pass.

Glass fiber reinforced foil (dark) 0,3mm: 3mm/s, 1 pass.



OptLasers.com



OptLasers.com



OptLasers.com



OptLasers.com

